

Ma

YEAR
7

LEVELS
3-4

2003

Year 7 mathematics test

Paper 2

Calculator allowed

Please read this page, but do not open your booklet until your teacher tells you to start. Write your name and the name of your school in the spaces below.

First name _____

Last name _____

School _____

Remember

- The test is 45 minutes long.
- You **may** use a calculator for any question in this test.
- You will need: pen, pencil, rubber, ruler, tracing paper and mirror (optional) and a calculator.
- This test starts with easier questions.
- Try to answer all the questions.
- Write all your answers and working on the test paper – do not use any rough paper. Marks may be awarded for working.
- Check your work carefully.
- Ask your teacher if you are not sure what to do.

For marker's
use only

Total marks	
-------------	--

Instructions

Answers



This means write down your answer or show your working and write down your answer.

Calculators



You **may** use a calculator to answer any question in this test.

1

The table shows information about pupils in a class.

	Number of boys	Number of girls
Right-handed	11	10
Left-handed	1	3

(a) Altogether, how many pupils in the class are **left-handed**?



.....

1 mark

(b) A **right-handed girl** leaves the class.

A **left-handed boy** joins the class.

Fill in the table for the class now.

	Number of boys	Number of girls
Right-handed		
Left-handed		

1 mark

2

Draw in and shade **3 triangles** so that the dashed line is a line of symmetry (a mirror line).

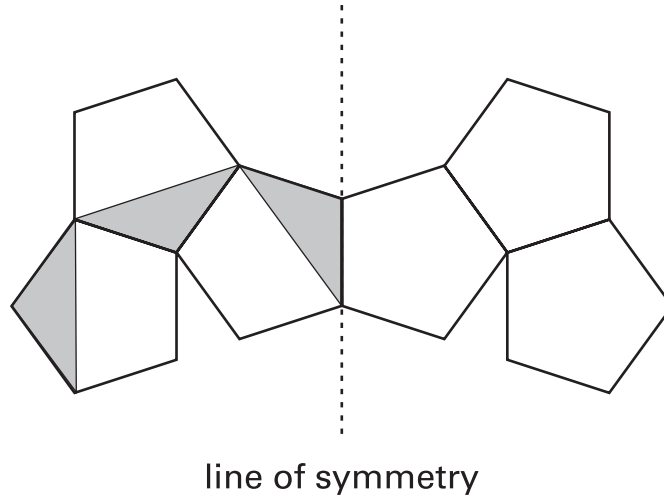

.....
2 marks

3

Rachel likes going to the theatre.

Each time she goes she pays for one ticket and one programme.

Ticket
£18.45

Programme
£2.50

In one year Rachel goes to the theatre **13 times**.

Altogether, how much does she pay?

Show your working.



£

.....
2 marks

- 4 This list shows the most popular names for boys born in 1904.

1st	William
2nd	John
3rd	George
4th	Thomas
5th	Arthur

Use the clues below to find the most popular names for boys born in 1924.

- George stayed in the same position.
- William and Thomas both went down by one place.
- The only new name in the list was James, which was less popular than John.



1st
2nd
3rd
4th
5th

.....
.....
2 marks

5

The arrow by this thermometer shows a temperature of **20°C**

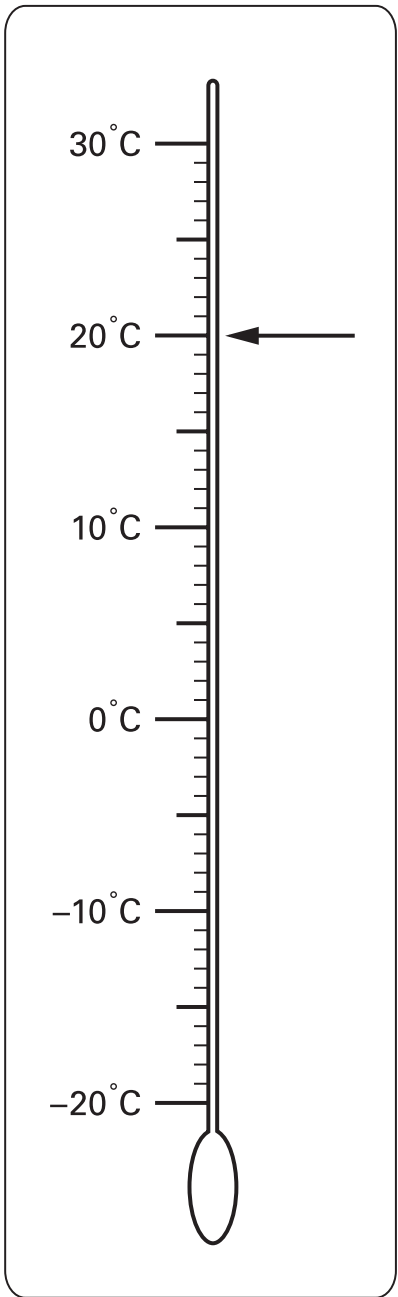

1 mark

1 mark

(a) Draw an arrow by the thermometer to show a temperature of **-8°C**

(b) The temperature was **-10°C**
It **went up** by **15°C**

What is the new temperature?



..... °C

(c) Write these temperatures in order, starting with the coldest.

-3°C

0°C

6°C

-9°C



coldest

warmest

1 mark

6

Some people are climbing down walls. The diagram shows their positions.

- (a) Write a fraction in each box to show about how far **down** the wall each person is. The first one is done for you.

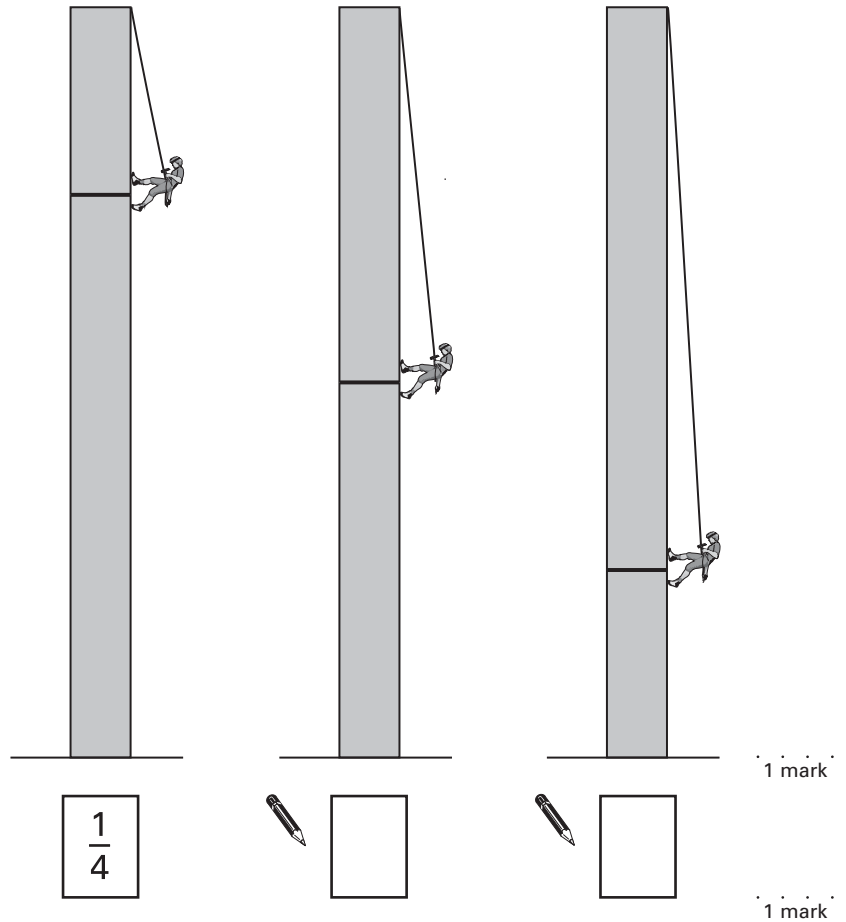

- (b) A different person is about $\frac{1}{3}$ of the way **down** the wall. **Draw a line** on the wall to show the person's position.

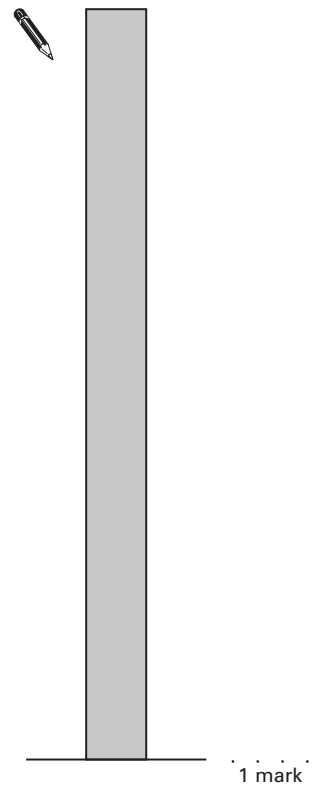

7 Which value completes each sentence? Tick (✓) the correct box.

The first one is done for you.

The **length** of a **banana** is about ...



- 2 cm
- 20 cm
- 200 cm
- 2000 cm

A **can of drink** holds about ...



- 0.3 litres
- 3 litres
- 30 litres
- 300 litres



1 mark

The **weight** of an **apple** is about ...



- 1 gram
- 10 grams
- 100 grams
- 1000 grams

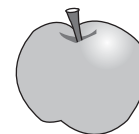

1 mark

8

Here is a triangle.

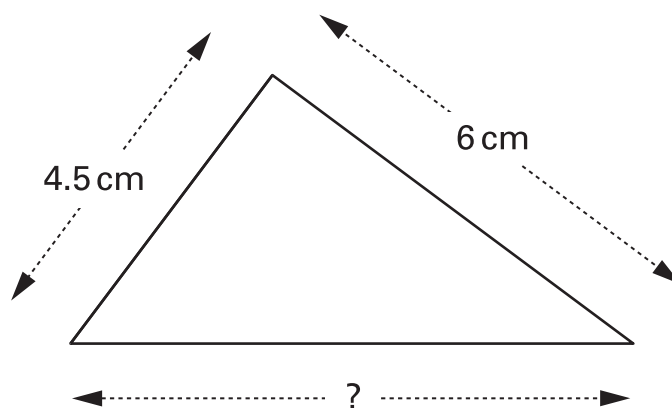

(a) Measure the length of the longest side.



1 mark

(b) What is the **perimeter** of this triangle?





1 mark

9

Alan went on holiday to Africa.

The pictogram shows how many animals he saw.

Key:  represents **20 animals**

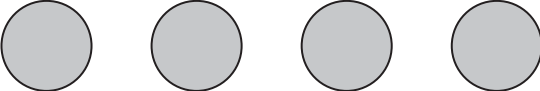
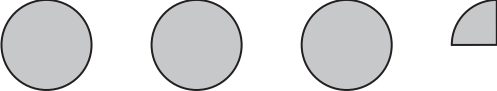
Lion	
Zebra	
Elephant	

(a) How many **lions** did Alan see?



.....

1 mark

(b) Alan saw more zebras than elephants.

How many more?



.....

1 mark

10 (a) Kate is using her computer to print a photo.

The **black** bar shows how much of the photo is printed so far.

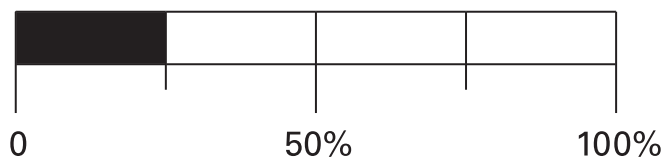

What **percentage** of the photo is printed so far?



..... %

1 mark

(b) Each photo takes **20 seconds** to print.

How many **minutes** will it take to print **15** photos?

Show your working.



..... minutes

.....

2 marks



11

Look at this shape.

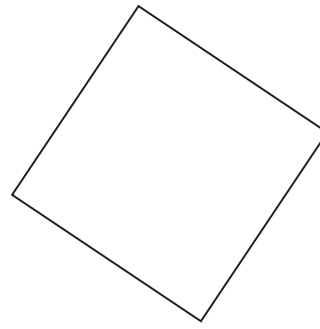

Complete the sentences.



The shape is a square so the sides must be

1 mark



The shape is a square so the angles must be

1 mark

12

This shape is drawn on a centimetre square grid.

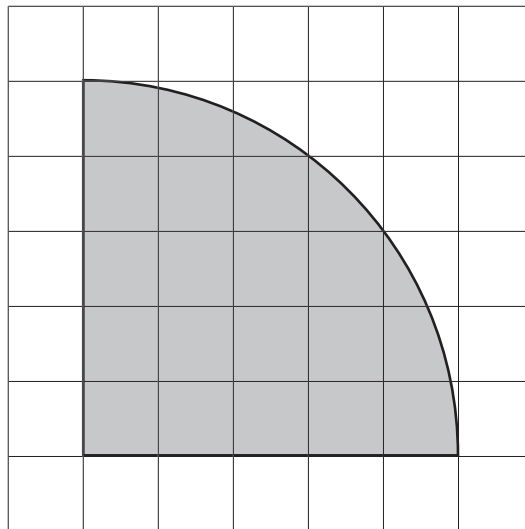
**Estimate** the **area** of the shape...... cm^2

1 mark

13

I join **three cubes** in a line to make this shape.

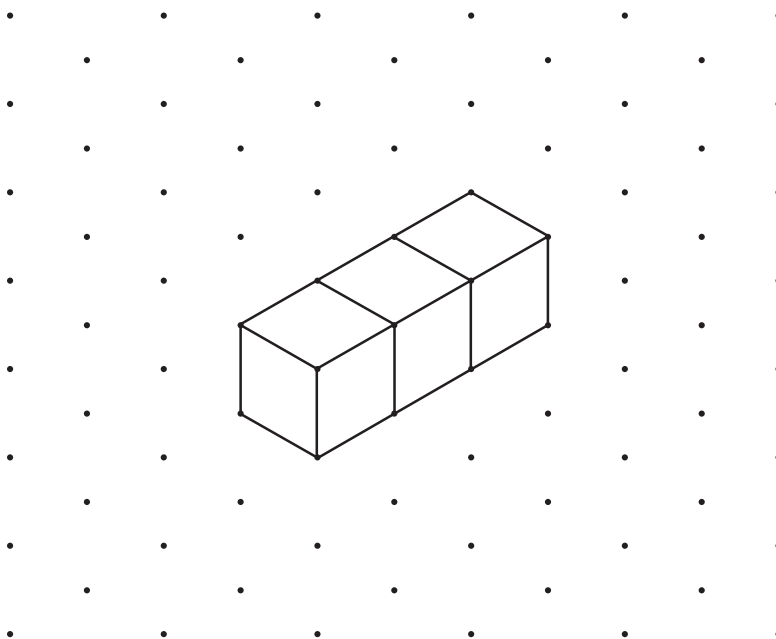

Then I join **one more cube** to make an **L-shape**.

Draw the L-shape on the paper below.



2 marks



- 14 (a) Gill puts **4 counters** in a bag.
3 counters are black. 1 counter is white.



Gill is going to take a counter out of the bag without looking.

What is the **probability** that the counter will be **white**?

Put a ring round the correct answer.



$$\frac{1}{4}$$

$$\frac{1}{3}$$

$$\frac{1}{2}$$

$$\frac{1}{1}$$

1 mark

- (b) Sam puts **20 counters** in a different bag.
She is going to take a counter out of the bag without looking.

The **probability** that the counter will be red is $\frac{1}{2}$

How many red counters are in her bag?



.....

1 mark

15 Part of a square grid is shaded.

(a) **What fraction** of the grid is shaded?

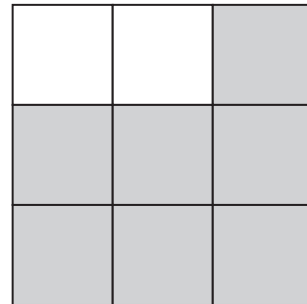

1 mark

The diagram shows the same grid after a **quarter turn clockwise**.

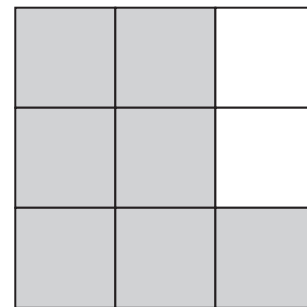

(b) Shade this diagram to show the grid after **another** quarter turn clockwise.

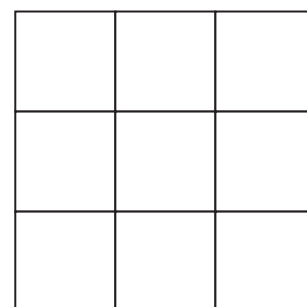

1 mark



16

The pie chart shows information about children who go to a nursery school.

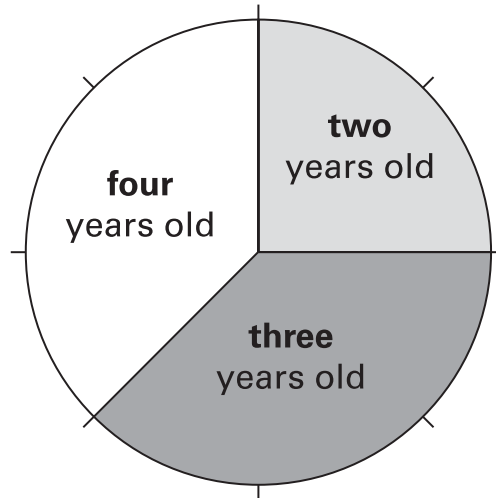

Altogether, **80 children** go to the nursery school.

(a) **How many** of the 80 children are **two** years old?



.....

1 mark

(b) **How many** of the 80 children are **four** years old?



.....

1 mark

17 (a) I think of a number. I call my number n

$$n$$

Then I add 5 to my number.

$$n + 5$$

The answer is 8

$$n + 5 = 8$$

What was my number?



$$n = \dots\dots\dots$$

1 mark

(b) Solve this equation to find the value of m

$$m - 2 = 8$$



$$m = \dots\dots\dots$$

1 mark

18

The diagram shows the volume of water in two measuring jugs.

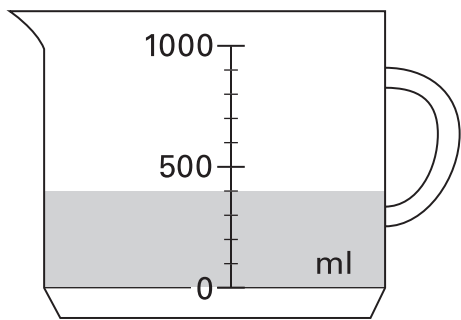

Jug A

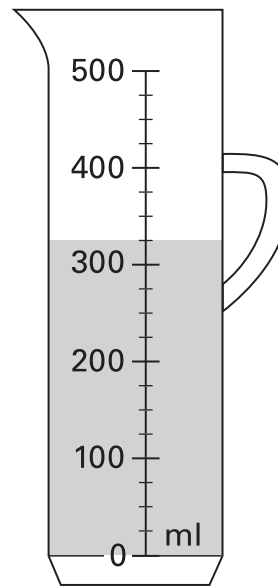

Jug B

Which jug contains **more** water?

Tick (✓) A or B.



A

B

How much more does it contain?

Show your working.

 ml

.....

2 marks

19 The **4th** square number is **16**

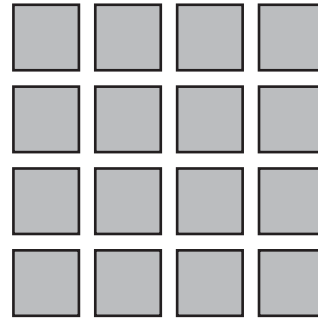

What is the **5th** square number?



.....

1 mark

20 A number line shows all the whole numbers from 1 to 100

Numbers that are **next to each other** on this line are called **consecutive numbers**.

Sanjay says:

'I can choose any **two** consecutive numbers.

When I **add** them the answer will **always** be an **even** number'.

Is Sanjay correct? Tick (✓) Yes or No.



Yes

No

Explain how you know.



1 mark



© **Qualifications and Curriculum Authority 2003**
QCA, Years 7 and 8 Team, 83 Piccadilly, London W1J 8QA

QCA/03/1028 (pupil pack)
QCA/03/1025 (teacher pack)

255007