

**KS3 MATHEMATICS**

***10 4 10***

**Level 8 Questions**

**Day 1**

**Mental Questions**

1. What number is five cubed?
2. A circle has radius  $r$ .  
What is the formula for the area of the circle?
3. Jenny and Mark share some money in the ratio two to three. Jenny's share is one hundred and ten pounds.  
How much is Mark's share?
4. The net of a triangular prism is made from triangles and rectangles.  
How many of each shape are needed?
5. Multiply minus six by minus two.

## Births

The table shows data about births in the UK.

Year	Number of births
1910	$1.05 \times 10^6$
1920	$1.13 \times 10^6$
1930	$7.69 \times 10^5$
1940	$7.02 \times 10^5$
1950	$8.18 \times 10^5$
1960	$9.18 \times 10^5$
1970	$9.04 \times 10^5$
1980	$7.54 \times 10^5$
1990	$7.99 \times 10^5$

- (a) In which year was the number of births the highest?



.....

1 mark

- (b) How many more births were there in 1990 than in 1980?

Show your working and write your answer in **standard form**.



.....

2 marks

## Trigonometry

- (a) Calculate the value of  $y$

Show your working.

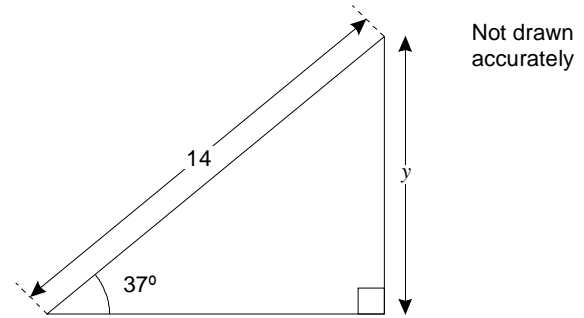

$y = \dots\dots\dots$  2 marks

Is it possible to have a triangle with the angles and lengths shown below?

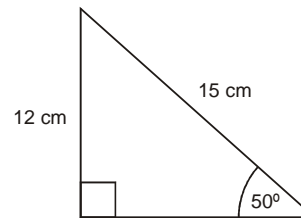

Calculations:



Decision:  Yes  No  
2 marks

**KS3 MATHEMATICS**

***10 4 10***

**Level 8 Questions**

**Day 2**

**Mental Questions**

1. What is one third of three-quarters of one hundred?
2. I'm thinking of a number. I call it  $n$ . I square my number then add four. Write an expression to show the result.
3. Twenty-one out of thirty-six pupils said they watched Top of the Pops. What angle would show this on a pie chart?
4. There are seven red and three blue balls in a bag. I am going to take a ball out of the bag at random. What is the probability that the ball will be blue?
5. Write a multiple of three that is bigger than one hundred.

### Enlargement

Here are four pictures, A, B, C and D. They are not to scale.

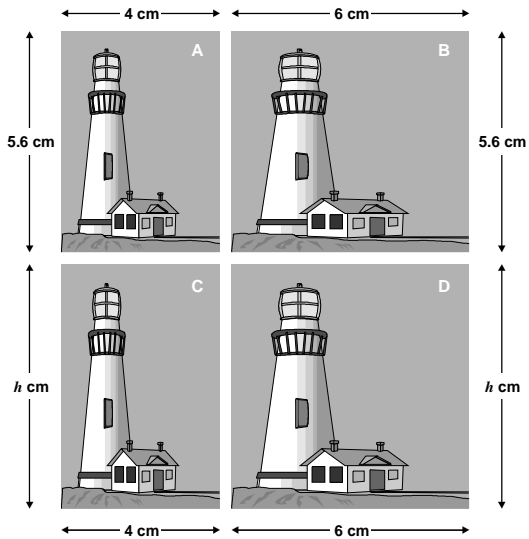

- (a) Picture A can be stretched horizontally to make picture B.  
Show that the horizontal factor of enlargement is **1.5**

1 mark

- (b) Picture A can be stretched vertically to make picture C.  
The vertical factor of enlargement is **1.25**

What is the height,  $h$ , of picture C?

..... cm

1 mark

- (c) Show that pictures A and D are **not** mathematically similar.

1 mark

- (d) Picture E (not shown) is mathematically similar to picture A.  
The width of picture E is **3 cm**  
What is the height of picture E?

### Factors

- (a) Look at these equations.

$$48 = 3 \times 2^a$$

$$56 = 7 \times 2^b$$

What are the values of  $a$  and  $b$ ?

  $a = \dots\dots\dots$        $b = \dots\dots\dots$

1 mark

- (b)  $48 \times 56 = 3 \times 7 \times 2^c$

What is the value of  $c$ ?

  $c = \dots\dots\dots$

1 mark

**KS3 MATHEMATICS**

**10 4 10**

**Level 8 Questions**

**Day 3**

**Mental Questions**

1. I am thinking of a number. I call it  $n$ .  
I double my number then I subtract three.  
Write an expression to show the result.
2. What percentage of fifty pounds is thirty-five pounds?
3. On average, the driest place on earth gets only nought point five millimetres of rain every year.  
In total, how much rain would it expect to get in twenty years?
4. To the nearest whole number, what is the square root of eighty-three point nine?
5. It takes me one and a half minutes to swim one length of the pool.  
How many lengths can I swim in fifteen minutes

## Box plots

A pupil recorded the heights of all the **girls in year 7**. She summarised her results, then drew this box plot.

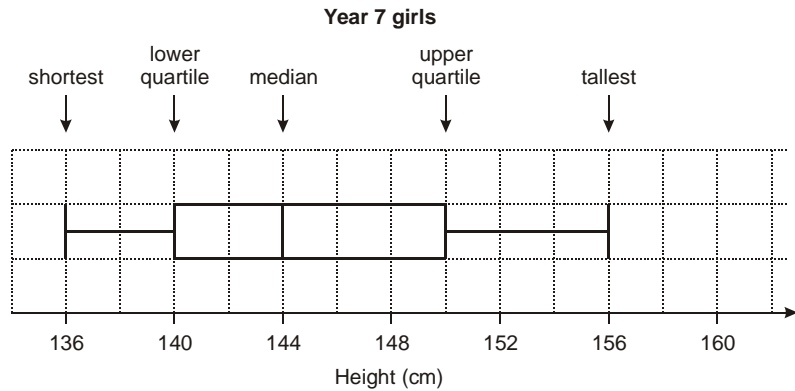

The pupil compared the heights of year 7 boys with year 7 girls.

- the shortest boy was the **same height** as the shortest girl;
- the **range** of boys' heights was **greater** than the range of girls' heights;
- the **inter-quartile range** of boys' heights was **smaller** than the inter-quartile range of girls' heights.

(a) Draw what the box plot for boys could look like.

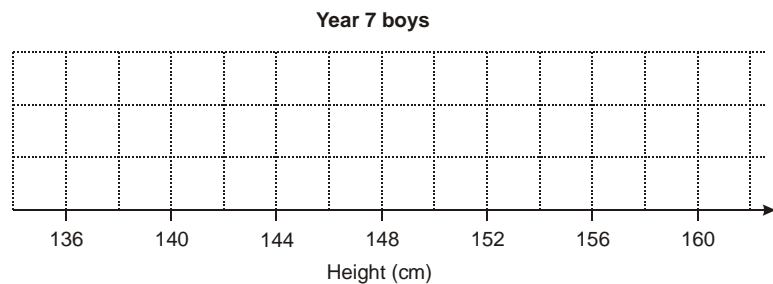

2 marks

There are 120 girls in **year 9**

The cumulative frequency diagram shows information about their heights.

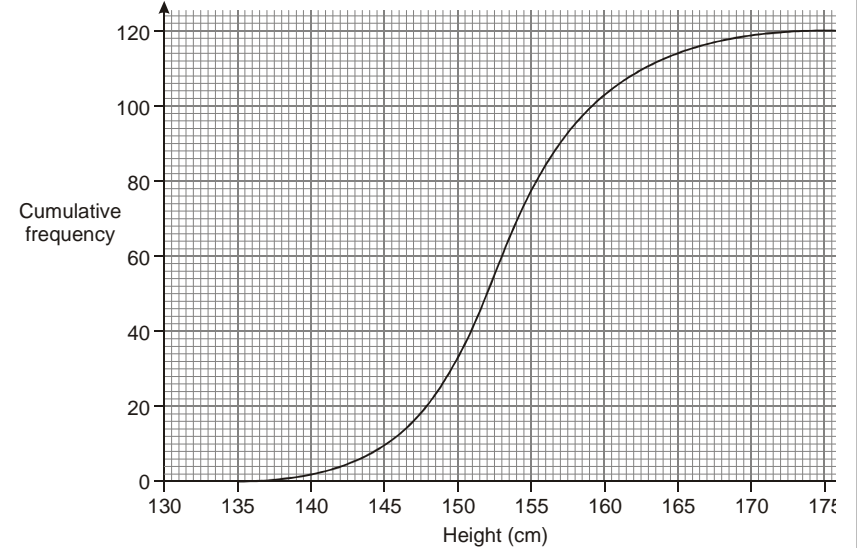

(b) Compare the heights of year 9 girls with year 7 girls.

3 marks



**KS3 MATHEMATICS**

**10 4 10**

**Level 8 Questions**

**Day 4**

**Mental Questions**

1. Tariq won one hundred pounds in a maths competition. He gave two-fifths of his prize money to charity. How much of his prize money, in pounds, did he have left?
2. What is three point nine divided by two?
3. The instructions for a fruit drink say to mix one part blackcurrant juice with four parts water. I want to make one litre of this fruit drink. How much blackcurrant juice should I use? Give your answer in millilitres.
4. What is half of two-thirds?
5. The population of the United Kingdom is about fifty-nine million. Write this number in figures.

A cup of coffee costs £1.75

The diagram shows how much money different people get when you buy a cup of coffee.

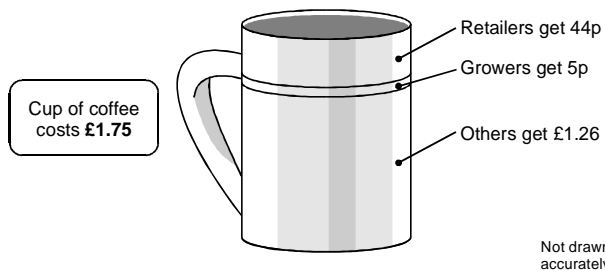

- (a) Complete the table to show what **percentage** of the cost of a cup of coffee goes to retailers, growers and others.

Show your working.



<b>Retailers</b>	%
<b>Growers</b>	%
<b>Others</b>	%

2 marks

- (b) Some people think the growers should get more. Suppose the percentages change to:

<b>Retailers</b>	23%
<b>Growers</b>	10%
<b>Others</b>	67%

- Suppose the **retailers** still got **44p** from each cup of coffee sold.  
How much would a cup of coffee cost?  
Show your working.



£

2 marks



## Graphs

Match each graph to the correct equation.

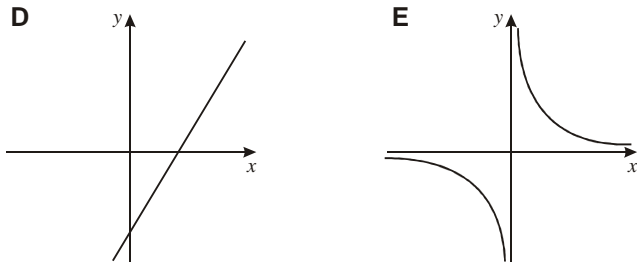
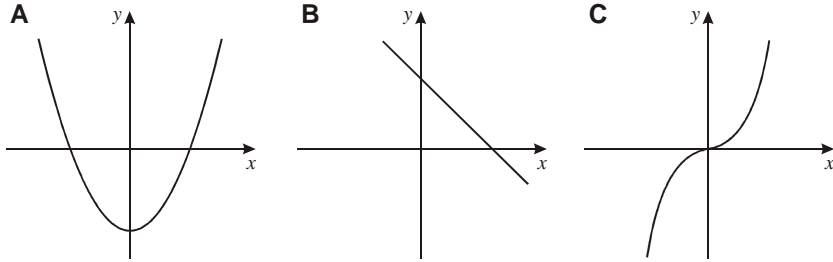

Graph ..... shows the equation  $y = 2x - 6$

Graph ..... shows the equation  $y = 6x^3$

Graph ..... shows the equation  $y = 6 - x$

Graph ..... shows the equation  $y = x^2 - 6$

Graph ..... shows the equation  $y = \frac{1}{6x}$

2 marks

## Tiles

A pupil has three tiles.

One is a regular octagon, one is a regular hexagon, and one is a square.

The side length of each tile is the same.

The pupil says the hexagon will fit exactly like this.

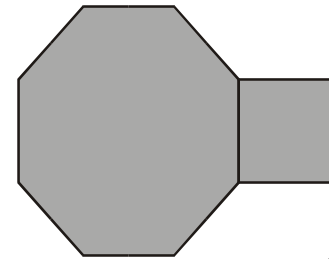

Not drawn accurately

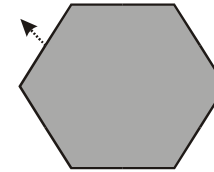

Show calculations to prove that the pupil is **wrong**.

3 marks

**KS3 MATHEMATICS**

***10 4 10***

**Level 8 Questions**

**Day 5**

**Mental Questions**

1. What is three-fifths of forty pounds?
2. The longest bone in the human body is in the leg. The average length of this bone in a man is fifty centimetres. In a woman it is ten per cent less. What is the average length of this bone in a woman?
3. Using three as an approximation for pi, what is the area of a circle with radius five centimetres?
4. I am thinking of a two-digit number that is a multiple of eight. The digits add up to six. What number am I thinking of?
5. I am thinking of a number. I call it  $n$ . I add five to my number. Write an expression to show the result.

**Plant Pots**

These plant pots are mathematically similar.  
The internal dimensions are shown.

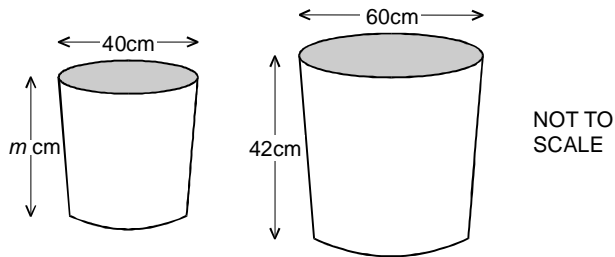

- (a) Calculate the value of  $m$ .

Show your working.



$m = \dots\dots\dots$  cm

2 marks

- (b) The capacity,  $C$ , of a plant pot in **cubic centimetres** is given by the formula:

$$C = \frac{1}{12} \pi h (a^2 + ab + b^2)$$

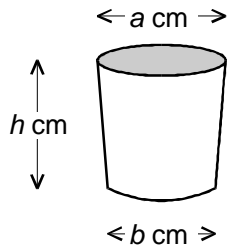

In the larger plant pot  $a = 60$ ,  $b = 36$  and  $h = 42$   
How many **litres** of compost are needed to fill the  
plant pot?

Show your working.



$\dots\dots\dots$  litres

3 marks

- (c) Think about the ratio of the widths of the two  
plant pots.

Explain why the ratio of the capacity of the smaller pot to  
the capacity of the larger pot is **8 : 27**



1 mark

## Languages

100 students were asked whether they studied French or German.

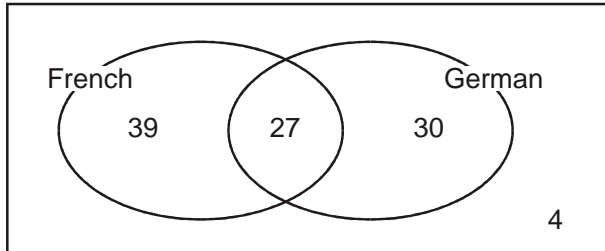

27 students studied both French **and** German.

- (a) What is the probability that a student chosen at random will study only **one** of the languages?



1 mark

- (b) What is the probability that a student who is studying German is also studying French?



1 mark

- (c) Two of the 100 students are chosen at random.

Circle the calculation which shows the probability that **both** the students study French and German?



$$\frac{27}{100} \times \frac{26}{100}$$

$$\frac{27}{100} \times \frac{26}{99}$$

$$\frac{27}{100} \times \frac{27}{100}$$

$$\frac{27}{100} \times \frac{26}{100}$$

$$\frac{27}{100} \times \frac{27}{100}$$

1 mark

## Scores

- (a) A fair coin is thrown. When it lands it shows heads or tails.

Game: Throw the coin **three** times.

Player **A wins** one point each time the coin shows a **head**.

Player **B wins** one point each time the coin shows a **tail**.

Show that the probability that player A scores three points is  $\frac{1}{8}$



1 mark

- (b) What is the probability that player B scores exactly **two** points?

Show your working.



2 marks



**KS3 MATHEMATICS**

**10 4 10**

**Level 8 Questions**

**Day 6**

### Mental Questions

1. Five percent of a number is 8. What is the number?
2. A fair spinner has eight equal sections with a number on each section. Five of them are even numbers. Three are odd numbers. What is the probability that I spin an even number?
3. I can make a three-digit number from the digits two, three and four in six different ways. How many of these three-digit numbers are even?
4. What is the volume of a cuboid measuring five centimetres by six centimetres by seven centimetres?
5. What is the remainder when you divide three hundred by twenty-nine?

**Theme Park**

Tom did a survey of the age distribution of people at a theme park.

He asked **160 people**.

The cumulative frequency graph shows his results.

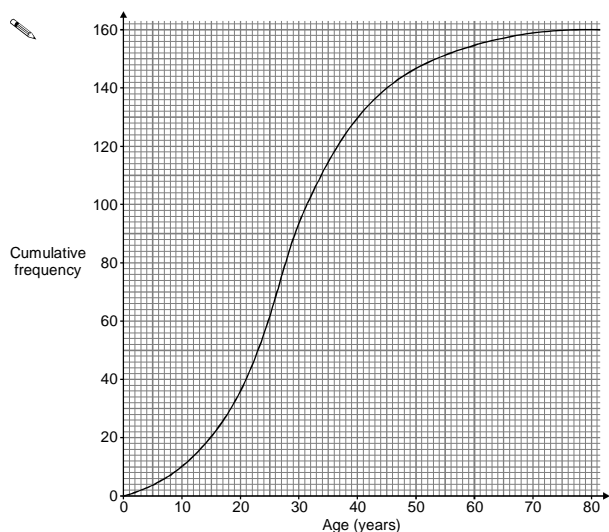

(a) Use the graph to estimate the **median** age of people at the theme park.

 median = .....years

1 mark

(b) Use the graph to estimate the **interquartile range** of the age of people at the theme park.

Show your method on the graph.

 interquartile range = .....years

2 marks

(c) Tom did a similar survey at a flower show.

Results: The **median** age was **47 years**.  
The **interquartile range** was **29 years**.

Compare the age distribution of the people at the flower show with that of the people at the theme park.



1 mark

**Eating**

People were asked if they were considering changing what they eat.

**29%** of the people asked said yes.

**Of these, 23%** said they were considering becoming vegetarian.

What **percentage** of the **people asked** said they were considering becoming vegetarian?

 ..... %

1 mark

**KS3 MATHEMATICS**

***10 4 10***

**Level 8 Questions**

**Day 7**

**Mental Questions**

1. Twenty-five per cent of a number is seven.  
What is the number?
2. There are fourteen girls and thirteen boys in a class.  
What is the probability that a pupil chosen at random will be a girl?
3. The first even number is two.  
What is the hundredth even number?
4. The mean of two numbers is 8. One of the numbers is two. What is the other number?
5. How many edges are there on a square based pyramid?

### Tanks

On a farm many years ago the water tanks were filled using a bucket from a well.

- (a) The table shows the numbers of buckets, of different capacities, needed to fill a tank of capacity 2400 pints.

Complete the table:

Capacity of bucket (pints)	8	10	12	15	16		
Number of buckets			200		150	100	80

- (b) Write an equation using symbols to connect **T**, the capacity of the tank, **B**, the capacity of a bucket, and **N**, the number of buckets.



1 mark

- (c) Now tanks are filled through a hosepipe connected to a tap.  
The rate of flow through the hosepipe can be varied.

The tank of capacity **4000** litres fills at a rate of **12.5** litres per minute.

How long in hours and minutes does it take to fill the tank?

Show your working.



..... hours ..... minutes

2 marks

- (d) Another tank took **5 hours** to fill at a **different rate** of flow.  
How long would it have taken to fill this tank if this rate of flow had been increased by **100%**?



..... hours ..... minutes

1 mark

- (e) How long would it have taken to fill this tank if the rate of flow had been increased by only **50%**?  
Show your working.



..... hours ..... minutes

2 marks

- (f) This tank, measuring **a** by **b** by **c**, takes 1 hour 15 minutes to fill.

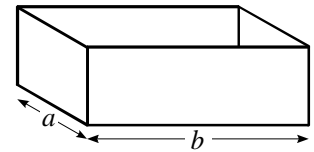

How long does it take to fill **2a** by **2b** by **2c**, at the same rate of flow?

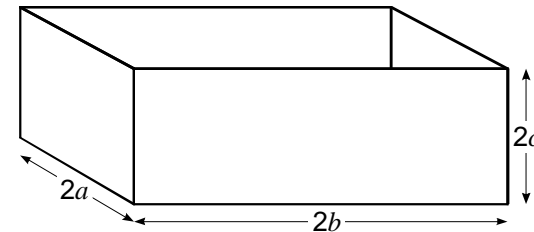

Show your working.



2 marks



**KS3 MATHEMATICS**

***10 4 10***

**Level 8 Questions**

**Day 8**

**Mental Questions**

1. Multiply 8.7 by 2
2. A bat flies at an average speed of 32 kilometres an hour. At this speed, how far will it fly in 15 minutes?
3. Multiply the brackets  $(2x + 1)(x - 1)$
4. I'm thinking of a number. I call it  $t$ . I half it and subtract five. Write an expression to show the result.
5. The first odd number is 1. What is the hundredth odd number?

### Squares

Some numbers are **smaller** than their squares.

For example:  $7 < 7^2$

- (a) Which numbers are **equal to** their squares?



2 marks

- (b) Some numbers are **bigger** than their squares.

Describe this set of numbers.



2 marks

### Expressions

- (a) This solid is a prism, with height  $3x$ .  
The cross-section is shaded.

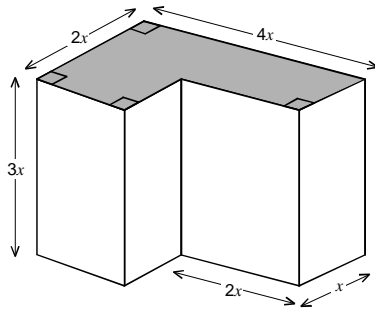

Not to scale

Write an expression for the **volume** of the prism.

Show your working and simplify your expression.



2 marks

The volume of this prism is given by the expression  $8x^3 \sin a$

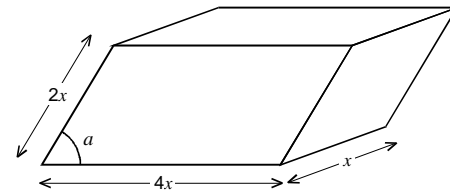

NOT TO SCALE

- (b) What value of  $a$  would make the volume of the prism  $8x^3$ ?



1 mark

$a = \dots\dots\dots^\circ$

- (c) The prism has a volume of  $500\text{cm}^3$ .  
The value of  $a$  is  $30^\circ$

What is the value of  $x$ ?

Show your working.



$x = \dots\dots\dots \text{cm}$

2 marks

## Algebraic expressions

Look at these expressions.

$$5y - 8$$

first  
expression

$$3y + 5$$

second  
expression

- (a) What value  $y$  of makes the two expressions equal?

Show your working.



$$y = \dots\dots\dots$$

2 marks

- (b) What value of  $y$  makes the first expression **twice** as great as the second expression?

Show your working.



$$y = \dots\dots\dots$$

2 marks



**KS3 MATHEMATICS**

***10 4 10***

**Level 8 Questions**

**Day 9**

## Mental Arithmetic Questions

1. Add four to minus five.
2. What number should you add to minus three to get the answer five?
3. How many nought point fives are there in ten?
4. On average, the driest place on earth gets only nought point five millimetres of rain every year. In total, how much rain would it expect to get in twenty years?
5. What is the sum of the angles in a rhombus?

**Which is Bigger?**

The diagram shows parts of two circles, sector A and sector B

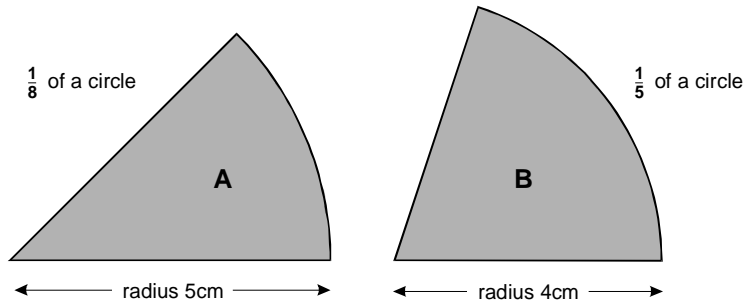

(a) Which sector has the **bigger area**?

Show working to explain your answer.



2 marks

(b) The perimeter of a sector is made from two straight lines and an arc.

Which sector has the **bigger perimeter**?

Show working to explain your answer.



2 marks

(c) A semi-circle, of radius 4cm, has the **same area** as a complete circle of radius  $r$  cm

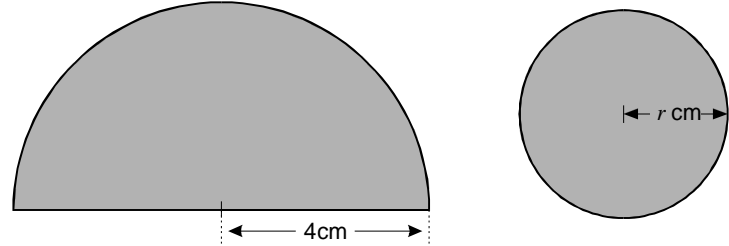

What is the radius of the complete circle?  
Show your working



$r = \dots\dots\dots$  cm

2 marks

## Mental Questions

1. It takes some-one one and a half minutes to swim the length of the pool. How many lengths can I swim in 15 minutes?
2. Multiply minus eight by minus three.
3. If  $4x + 3 = 23$ , what is the value of  $x$ ?
4. I have a fair eight sided dice numbered 12 to 19. What is the probability that I will throw a prime number?
5. What must I multiply  $n$  squared by to get  $n$  cubed?



**KS3 MATHEMATICS**

***10 4 10***

**Level 8 Questions**

**Day 10**

## Thomas the Tank Engine

The first 'Thomas the Tank Engine' stories were written in 1945.

In the 1980s, the stories were rewritten.  
The cumulative frequency graph shows the numbers of words per sentence for one of the stories.

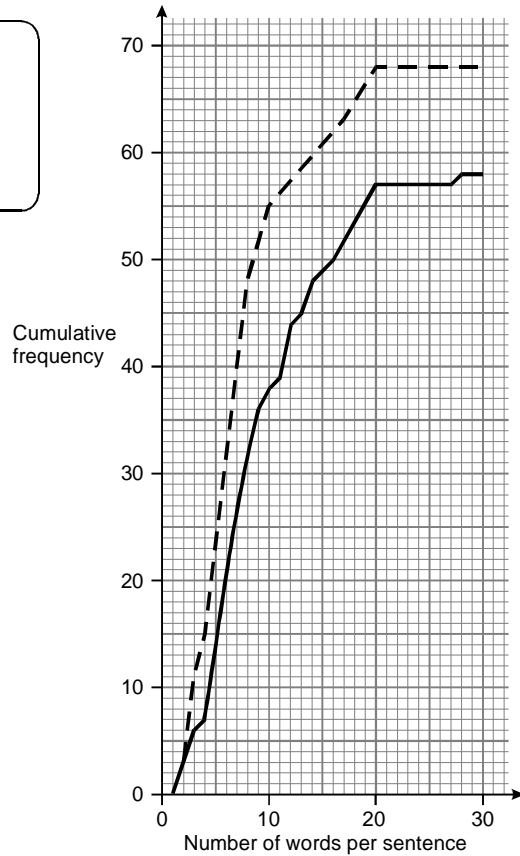
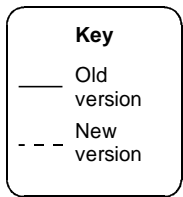

There are **58 sentences** in the old version.

There are **68 sentences** in the new version.

3 marks

- (a) Estimate the **median** number of words per sentence in the old version and in the new version.  
Show your method on the graph.

 old .....

 new .....

3 marks

- (b) What can you tell from the data about the number of words per sentence in the old version and in the new version?



1 mark

- (c) Estimate the percentage of sentences in the **old** version that had more than 12 words per sentence.  
Show your working.



..... %

2 marks